



EYE AND EYE TAIL SPLICE

NOTE: These instructions are intended for use with Samson's Tenex, Tenex-Tec (2 end per carrier Tenex), IceTail, or Tech-12 only.

The desired tail length will dictate the starting length of cordage required. For a 33" finished Eye and Eye Tail, an 80" length of 3/8" rope is required.

STEP 1 TAIL LENGTH

Mark the center point of the rope. This is mark A. Bring both ends of the rope towards the center point as shown and overlap the tails 1-1/2"

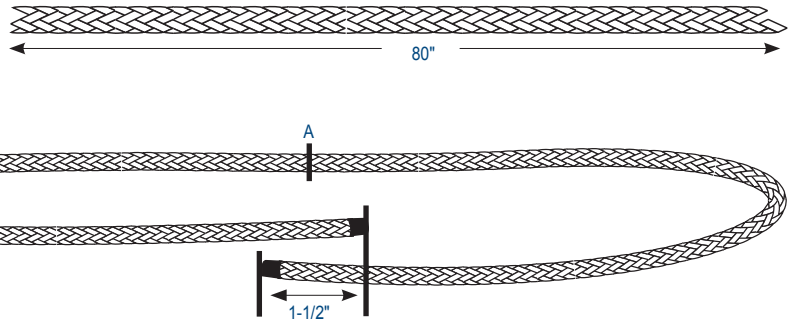

STEP 2 MARK EYE SIZES

Mark the size of the eye on each tail. From the inside of the eye, mark both legs of the eye at 1-1/4". These are marks B and C, as shown.

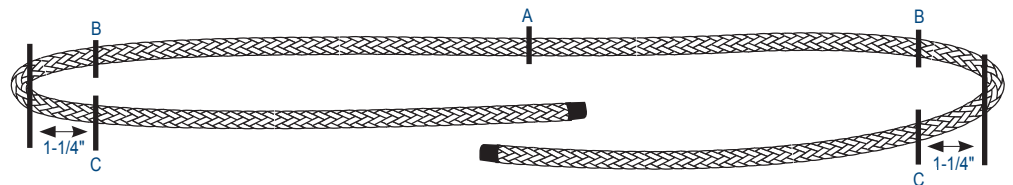

STEP 3 MARK AND PULL TAPERS

Mark the tapers. From mark C towards the ends, count twelve strand pairs and begin taper marks on the thirteenth pair. Mark both a left hand and a right hand strand pair at each point for removal. Mark the 13th, 15th, and 17th. You should have a total of six strand pairs marked for removal at each end. Pull the marked strands from the rope, but do not cut. Replace the tape on both ends of the rope.

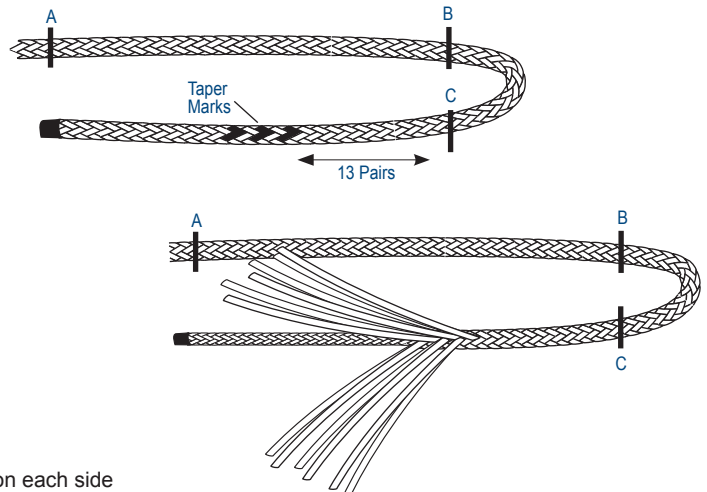

STEP 4 MARK EXIT POINTS

From the midpoint marked in step 1, measure four inches on each side of the center mark and make a mark. These will be the exit points X.

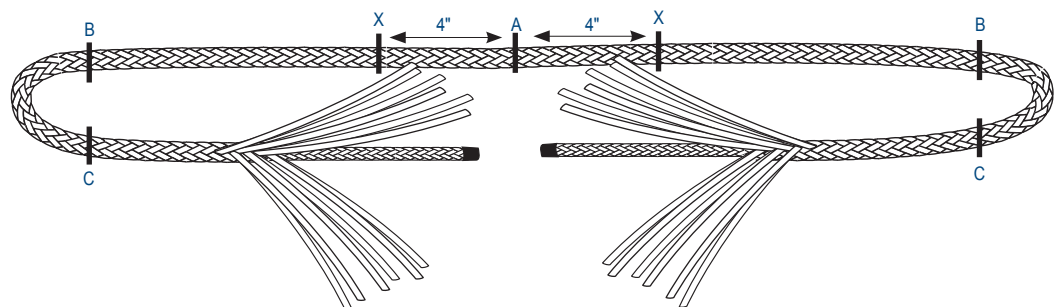



EYE AND EYE TAIL SPLICE

STEP 5 FORM AND CLOSE BRUMMEL

5A Form the locked Brummel on both ends. Pass the shorter taped end through the center of the rope at mark B. Do not bury mark C, leave on the entry side of standing rope.

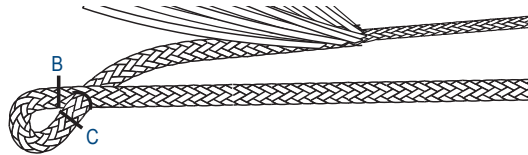

5B Pass the opposite end through the center of the tail approximately two picks from where it exits the standing part of the rope. Close up the Brummel, bringing marks B and C together at the vertex of the eye.

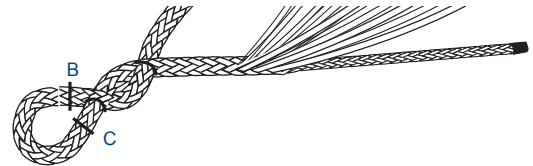

STEP 6 BURY TAILS

Measure 2 picks from the point where the standing part passes through the tail. This is mark D.

With a fid attached to the taped end of the tail, bury the tail from mark D past the midpoint A to mark X. Just before the pulled taper strands are buried into the standing part of the rope, cut them off. Pull the tail out at mark X as far as possible, and repeat steps 5, 6, and 7 for the opposite end.

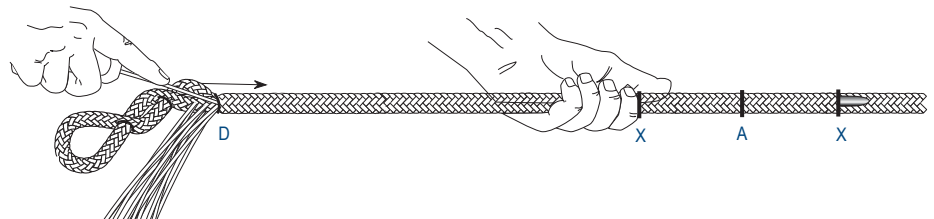
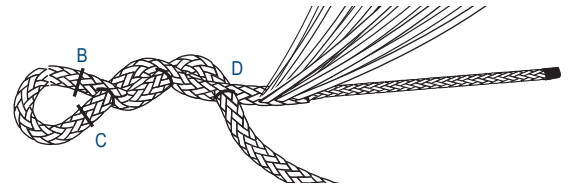

STEP 7 MARK AND CUT ENDS

Smooth all slack from the rope, working from the Brummels to the center mark. Mark where the tapered ends exit the rope at both marks X. Pull both tapered ends out from mark X, measure 3-1/2" from previous mark where the tapers exited at mark X (this is the section of both tapered ends that overlap in the center section), and cut off at an angle.

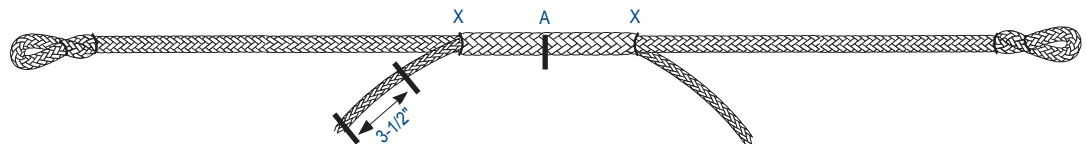

STEP 8 FINISH SPICE

Milk all slack from the Eye and Eye Tail. The goal is to keep the diameter and fullness of the rope consistent tied into a climbing hitch. When all slack has been removed and the diameter is consistent, lock stitch the eyes at both ends.

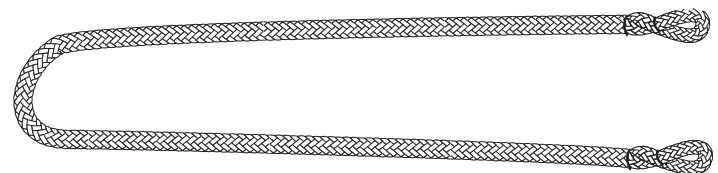



LOCK STITCHING & WHIPPING PROCEDURES

LOCK STITCHING:

STEP 1

Pass stitching through spliced area near throat of eye as shown.

STEP 2

Reinsert as shown pulling snug but not tight.

STEP 3

Continue to reinsert as shown until you have at least 3 complete stitches.

STEP 4

After completing Step 3, rotate spliced part of rope 90° and reinsert end A into spliced area in the same fashion as in Steps 1, 2 and 3. The splice will now be stitched on two planes perpendicular to each other. Make sure you do not pull the stitching too tight.

STEP 5

After stitching at least three complete stitches as in Step 3, extract both ends A and B together through the same opening in the braid. Tie them together with a square knot and reinsert back into braid. For double braids, re-insert the knot between the cover and core.

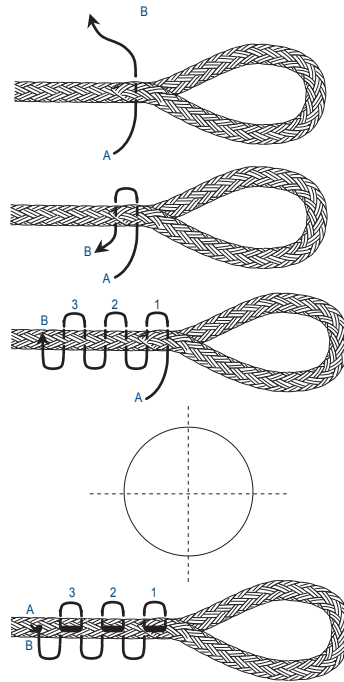

Twines for Lock Stitching:

In general, braided nylon twine is preferred for lock stitching. Polyester twines, or twisted twines in either polyester or nylon, or a strand from the rope itself (from a discarded or extra piece) can be substituted.

The twine used should be approximately the same diameter as a strand in the rope. If the rope or the cover of the rope is made up of pairs of strands rather than a single strand, the twine should be about the same diameter as these two strands together.

To check the twine size, lay the twine over the strands in the rope – if it covers the width of the strand(s), it is the right size.