

# SAMSON SPLICING INSTRUCTIONS

## 12-Strand Class II Tuck-Bury End-for-End Splice FOR SATURN-12™



This is a modification to the standard HMPE Tuck-Bury 12-strand splice to increase splice length on Saturn-12. This modification must be used on Saturn-12 products larger than 1-1/4" (30mm) in diameter.

### STEP 1 MEASURING AND MARKING

Tape the ends of the ropes to be spliced. Lay Ropes A and B side-by-side and measure 2 tubular fid lengths (4 wire fids) from the taped end of each line and make Mark 1. Tightly tape the rope at Mark 1.

**1A** From Mark 1, measure 2-1/2 fid lengths and make Mark 2 on both ropes.

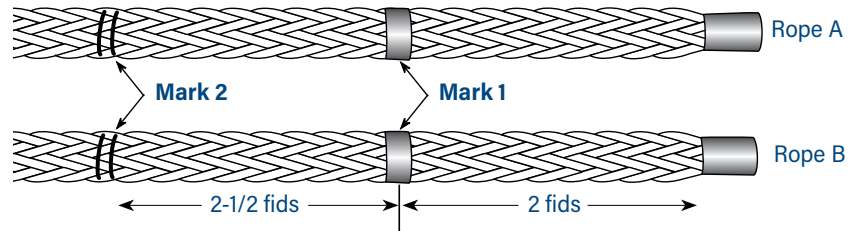

### STEP 2 TAPERING THE TAIL

At Mark 1, pull out half the strands (3 "S" and 3 "Z") by rotating around the rope, pulling out strands in the pattern shown:

Z Strands = counter clockwise twist  
S Strands = clockwise twist

This should leave 6 strands still braided down the middle. Tightly tape the ends of the 6 individual strands, and the end of the remaining braided portion.

**2A** On 1 side you should have 2 S and 1 Z and on the other side, 2 Z and 1 S.

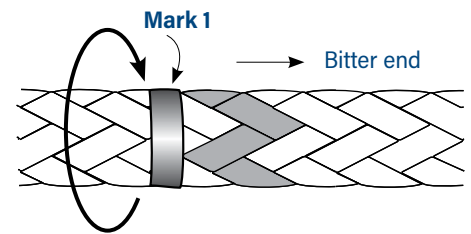

**TIP:** Tape the ends of the S and Z strands with different tape colors for ease of identification while splicing.

### STEP 3 ROUTING THE STRANDS

Reposition the ropes for splicing according to the diagram. Make sure each strand has as little twist as possible.

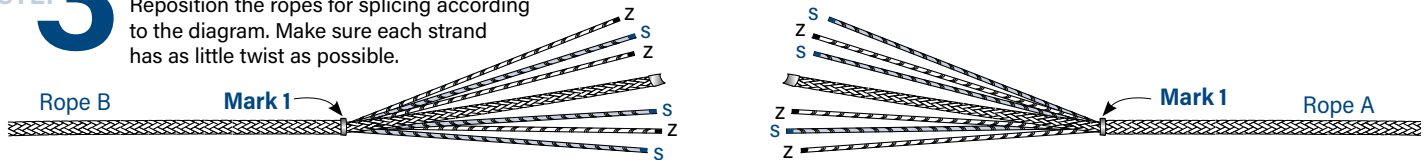

### STEP 4 BURYING THE TAIL OF ROPE A INTO ROPE B

From Rope A, pass the 3 closest strands to Rope B through Rope B, 1 or 2 picks down from Mark 1. Do not pull strands all the way through at this stage. The strands enter at the entry point 2 picks from Mark 1, and exit at the exit points 2 picks from the entry point.

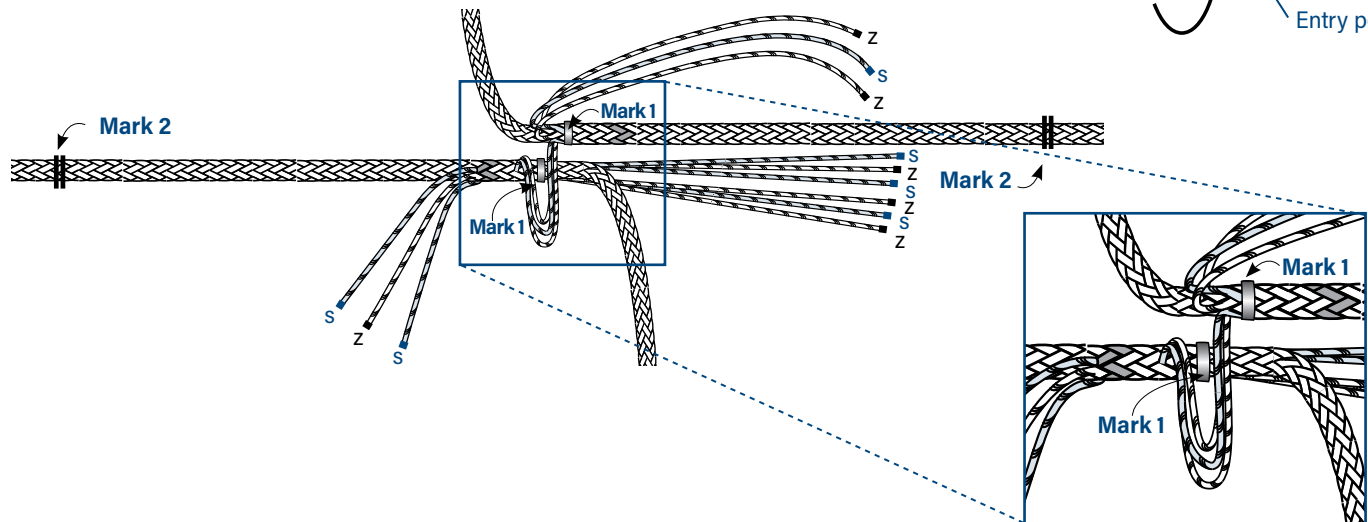
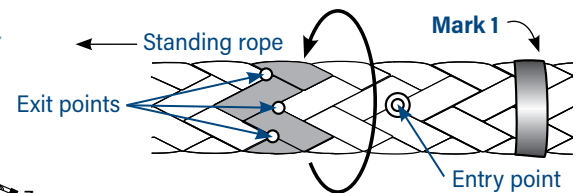

# 12-Strand Class II Tuck-Bury End-for-End Splice FOR SATURN-12™



**4A** Bury the remaining braided strands down the center of the rope, entering at Mark 1 and exiting at Mark 2. The tail should enter the standing part of the rope at the same point where the 3 loose strands passed through. Pull the tail out at Mark 2.

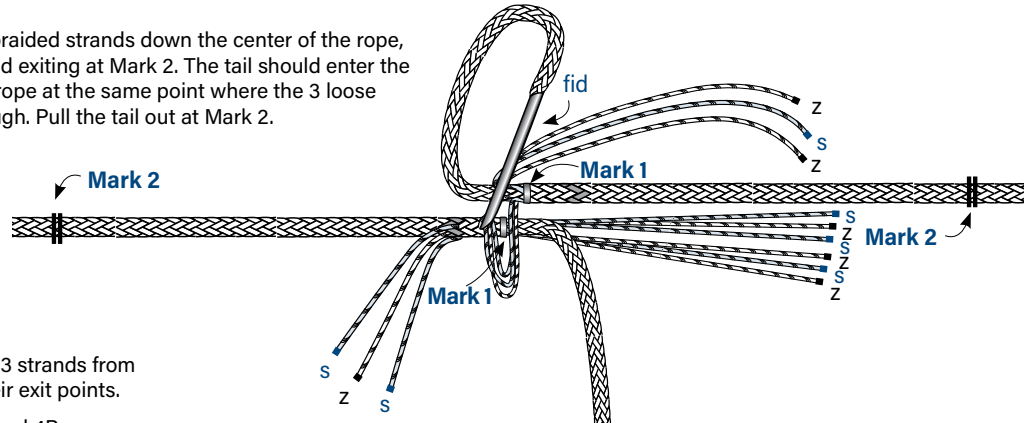

**4B** Route the remaining 3 strands from the entry point to their exit points.

Repeat Steps 4, 4A, and 4B on the opposite end of the rope.

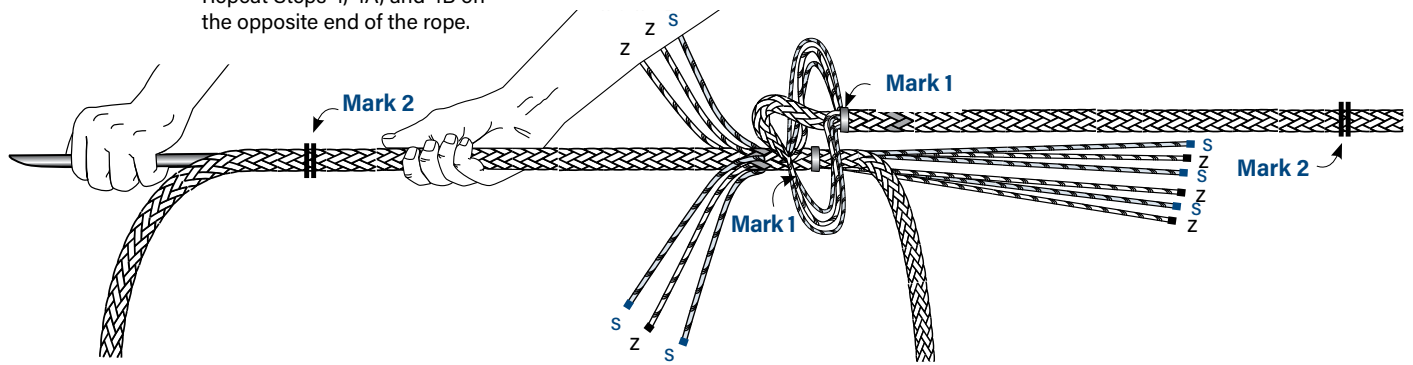

## STEP 5 TAPERING THE TAILS

At the end of the tapered tail, remove the fid and any tape at the end of the tail. From the end of the tail, mark 3 consecutive strands, as shown. Pull them out of the braid and cut off close to the body of the rope.

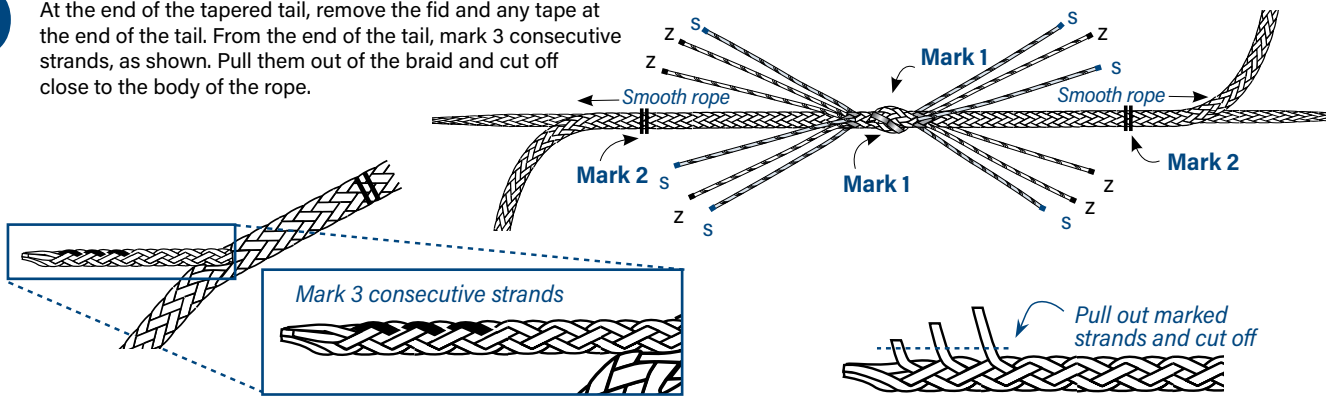

**5A** Remove the tape from the end of the tails. Now smooth the rope from the crossover toward Mark 2 to bury the tails.

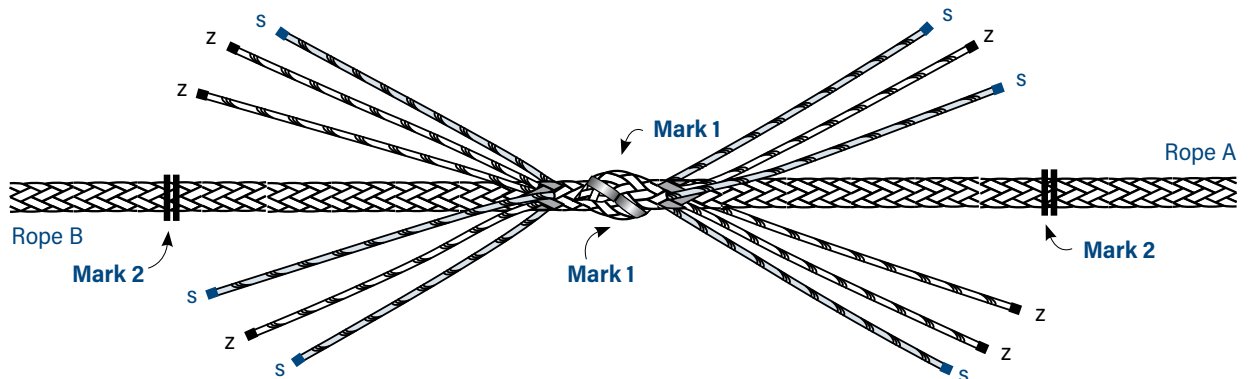

# 12-Strand Class II Tuck-Bury End-for-End Splice FOR SATURN-12™



## STEP 6 TUCKING THE STRANDS

Tuck the strands from Rope A into Rope B. 1 complete tuck consists of passing a strand over 1 strand and under 2 strands.

Do 5 complete tucks for all 6 strands. Each strand is always tucked under the same line of the braid so that the tucks progress straight down the body of the rope.

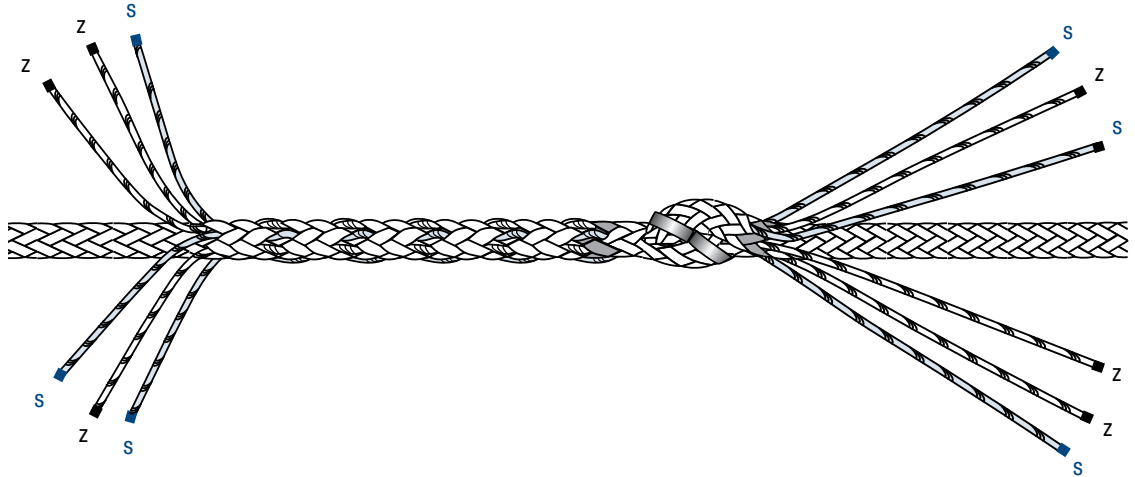

### 6A

After completing the first 5 tucks, remove half the volume of the twisted yarns from each of the 6 strands near the taped ends, and complete 3 more tucks with the reduced-volume strands.

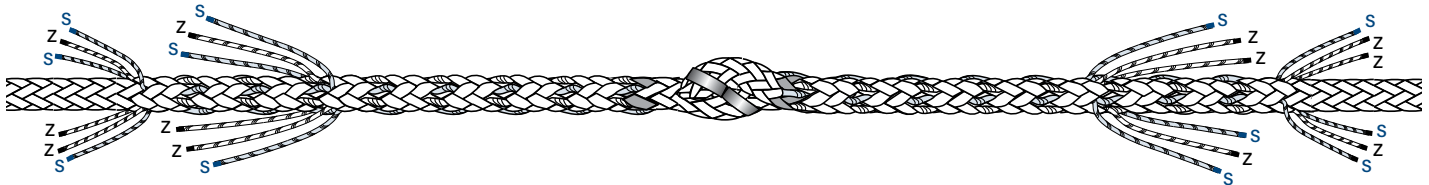

## STEP 7 GROUPING THE STRANDS

Group tail strand pairs with closest exiting point into 6 separate groups. There will be 12 groups total, 6 on each side of the splice.

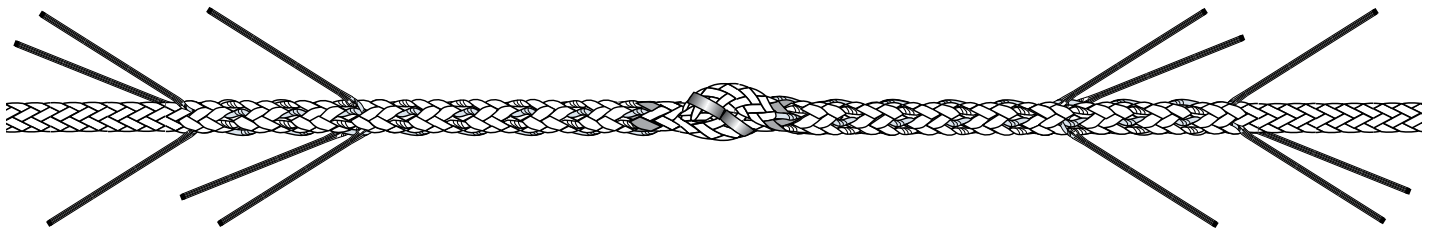

# 12-Strand Class II Tuck-Bury End-for-End Splice FOR SATURN-12™



STEP

# 8

## TUCKING PROCEDURE

Tuck previously grouped tail under 2 picks.

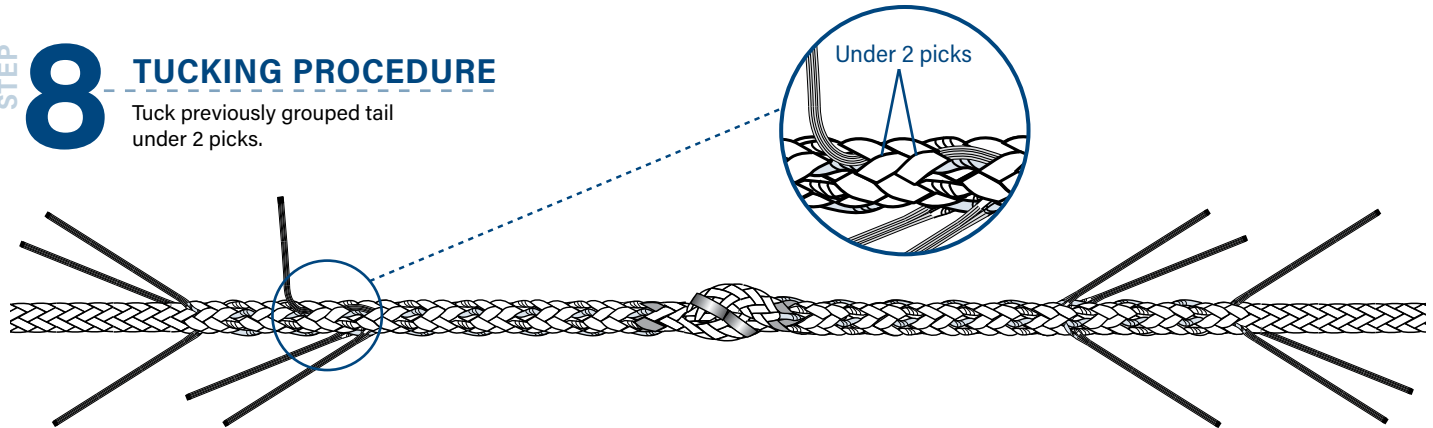

# 8A

Pass tail through to the other side, passing through the center of the rope.

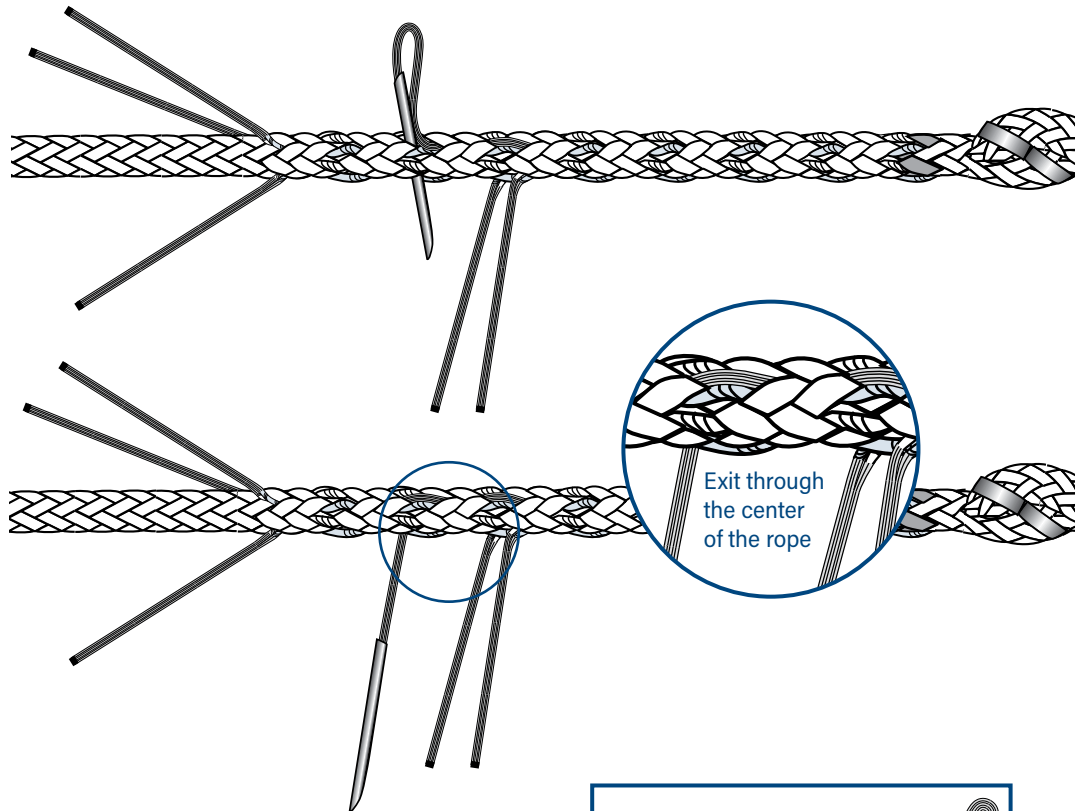

# 8B

Flip the rope over and pass tail under 3 picks, exit, and pull snug.

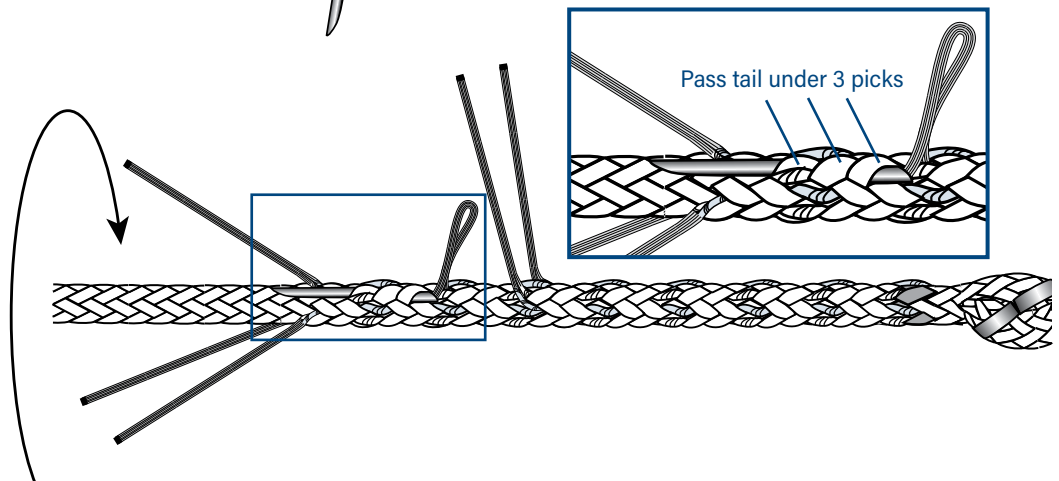

# 12-Strand Class II Tuck-Bury End-for-End Splice FOR SATURN-12™



**8C** Cut the excess strands flush with rope. **Be careful not to cut the body of the main rope.**

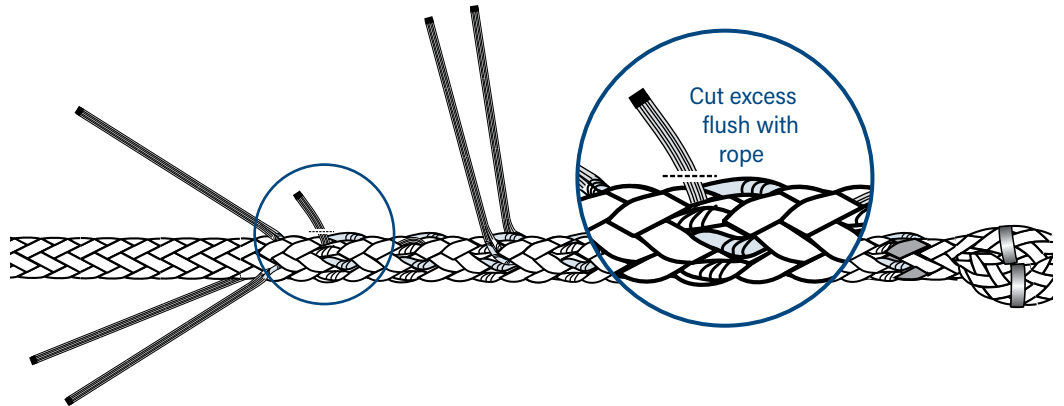

## STEP 9 FINISHING THE SPLICE

Your finished Saturn-12 Tuck-Bury End-for-End Splice will look like this:



Finished splice